

Model of two-fluid magnetic reconnection

Leonid Malyshkin

University of Chicago & Center for Magnetic Self-Organization (CMSO)

April 2010, Midwest Magnetic Fields Workshop

The problem setup & assumptions

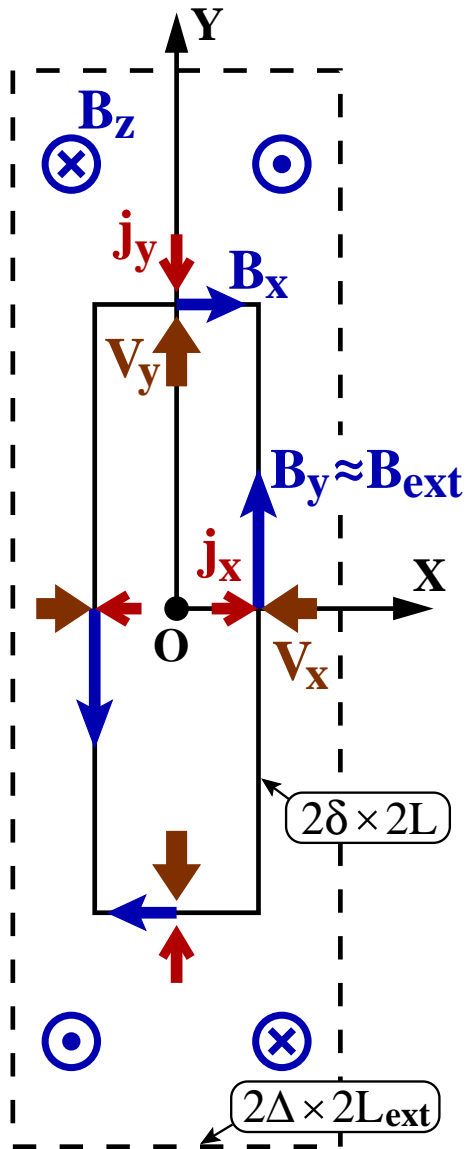

Assumptions:

- non-relativistic incompressible p^+ and e^- plasma;
- isotropic p^+ and e^- pressure, also neglect viscosity;
- resistivity η is constant & small (large Lundquist);
- a thin layer, 2-dimensional geometry $\partial/\partial z \equiv 0$;
- geometric symmetries of the layer, quadrupole B_z ;
- quasi-stationarity, $\partial/\partial t \approx 0$.

Notations:

- we use physical units in which $c = 1$ and $4\pi = 1$;
- 2δ and $2L$ are thicknesses and length of e^- layer;
- 2Δ and $2L_{ext}$ are thicknesses & length of p^+ layer;
- B_{ext} is upstream field (B_y at $y=0$ and $x \approx \Delta$);
- $V_A = B_{ext}/\sqrt{\rho}$ is Alfvén velocity, $\rho = m_p n = \text{const}$;
- $S = L_{ext} V_A/\eta$ is Lundquist number;
- $d_p = c/\omega_{pp} = \sqrt{m_p}/e\sqrt{n}$ and $d_e = c/\omega_{pe} = \sqrt{m_e}/e\sqrt{n}$ are the proton and electron inertial lengths.

Equations

- Equations of the motion of the e^- and p^+ :

$$nm_e[\partial_t \mathbf{u}^e + (\mathbf{u}^e \nabla) \mathbf{u}^e] = -\nabla P_e - ne(\mathbf{E} + \mathbf{u}^e \times \mathbf{B}) + nen\mathbf{j},$$

$$nm_p[\partial_t \mathbf{u}^p + (\mathbf{u}^p \nabla) \mathbf{u}^p] = -\nabla P_p + ne(\mathbf{E} + \mathbf{u}^p \times \mathbf{B}) - nen\mathbf{j}.$$

- Express \mathbf{u}^e and \mathbf{u}^p in terms of electric current $\mathbf{j} = ne(\mathbf{u}^p - \mathbf{u}^e)$ and center-of-mass velocity $\mathbf{V} = (m_p \mathbf{u}^p + m_e \mathbf{u}^e)/\rho$, also use $m_e \ll m_p$:

$$\mathbf{u}^p = \mathbf{V} + (m_e/m_p)\mathbf{j}/ne \quad \text{and} \quad \mathbf{u}^e = \mathbf{V} - \mathbf{j}/ne.$$

- Obtain generalized Ohm's law from the equation of e^- motion

$$\begin{aligned} \mathbf{E} = & -\mathbf{V} \times \mathbf{B} + \eta\mathbf{j} + \mathbf{j} \times \mathbf{B}/ne - (1/ne) [\nabla P_e - (d_e^2/d_p^2)\nabla P_p] - \\ & + d_e^2 [\partial_t \mathbf{j} + (\mathbf{V} \nabla) \mathbf{j} + (\mathbf{j} \nabla) \mathbf{V} - (1/ne)(\mathbf{j} \nabla) \mathbf{j}]. \end{aligned}$$

- Obtain momentum equation from the equation of p^+ motion

$$nm_p [\partial_t \mathbf{V} + (\mathbf{V} \nabla) \mathbf{V}] + d_e^2 (\mathbf{j} \nabla) \mathbf{j} = -\nabla P + \mathbf{j} \times \mathbf{B}, \quad P = P_e + P_p.$$

- Maxwell equations: $\nabla \times \mathbf{B} = \mathbf{j}, \quad -\partial_t \mathbf{B} = \nabla \times \mathbf{E}, \quad \nabla \cdot \mathbf{B} = 0.$

Equations (continue)

Ampere's Law z-component (at O-point):

$$j_o = (j_z)_o \approx \frac{B_{ext}}{\delta}$$

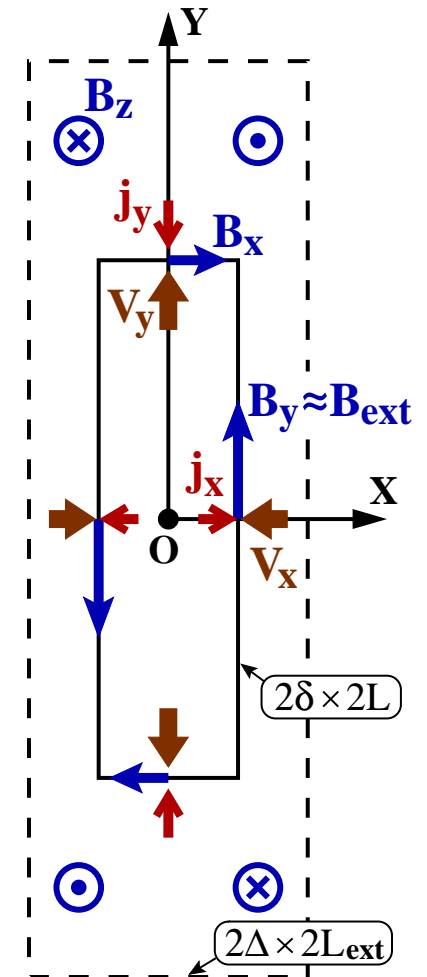

Equations (continue)

x -component of the momentum equation (force balance across the layer):

$$(\partial_{yy}P)_o \approx (\partial_{yy}B_y^2/2)_{ext} \approx -2B_{ext}^2/L^2$$

y -component of the momentum equation
(acceleration along the layer):

at the O-point, calculate $\partial/\partial y$ of

$$nm_p(\mathbf{V}\nabla)V_y + d_e^2(\mathbf{j}\nabla)j_y = -\partial_y P + j_z B_x - j_x B_z$$

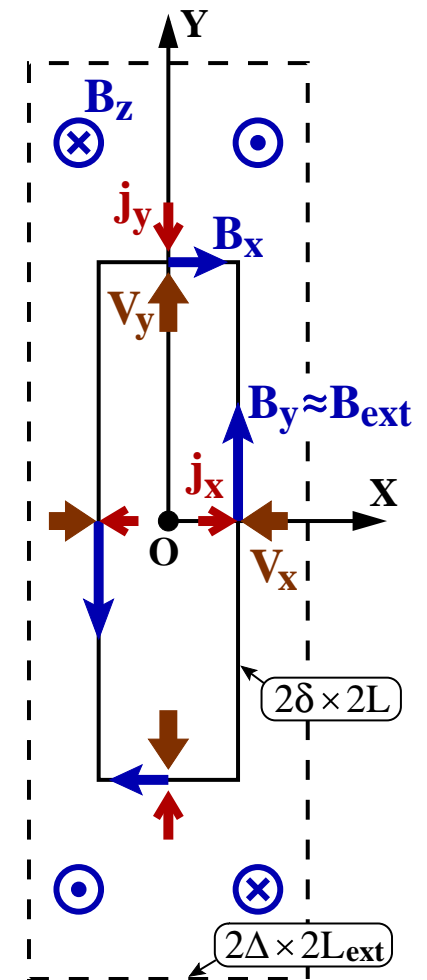

Equations (continue)

Faraday's Law x- and y-components:

$$(\nabla \times \mathbf{E})_x = \partial_y E_z = -\partial B_x / \partial t = 0,$$

$$(\nabla \times \mathbf{E})_y = -\partial_x E_z = -\partial B_y / \partial t = 0,$$

$\Rightarrow E_z = \text{constant in space}$

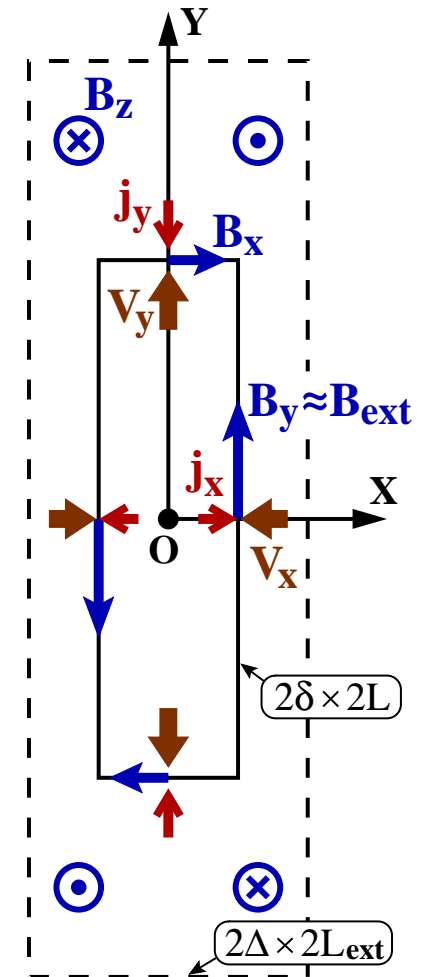

Equations (continue)

Ohm's Law z-component:

$$E_z = \eta j_z - V_x B_y + V_y B_x + (j_x B_y - j_y B_x)/ne \\ + d_e^2 [V_x \partial_x j_z + V_y \partial_y j_z + j_x \partial_x V_z + j_y \partial_y V_z \\ - (j_x \partial_x j_z + j_y \partial_y j_z)/ne] = \text{constant.}$$

- O-point: $E_z = \eta j_o$
- $E_z = \text{const}$ across the layer:

$$\partial_{xx} E_z = 0 \quad \text{at point O;}$$

$$\eta j_o = E_z(x \approx \delta, y=0) = E_z(x \approx \Delta, y=0)$$

- $E_z = \text{const}$ along the layer:

$$\partial_{yy} E_z = 0 \quad \text{at point O;}$$

$$\eta j_o = E_z(x=0, y \approx L)$$

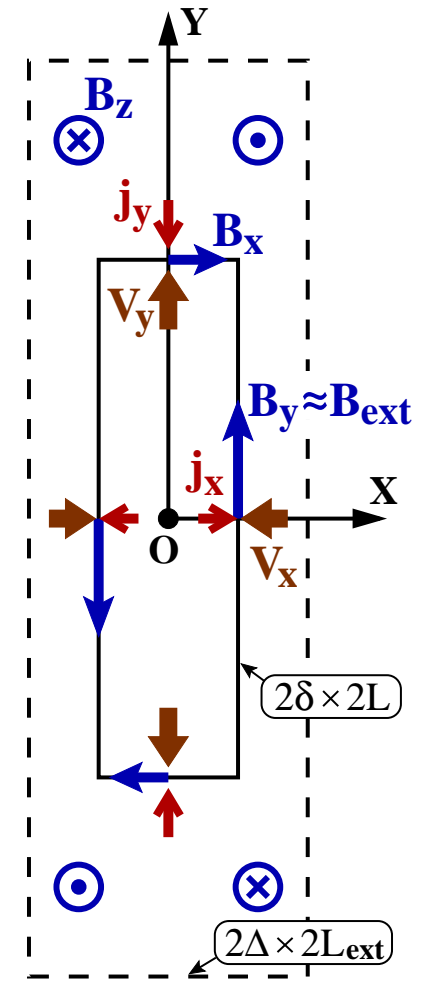

Equations (continue)

Faraday's Law z-component:

$$\partial_x E_y - \partial_y E_x = -\partial B_z / \partial t = 0$$

at the O-point, calculate $\partial^2 / \partial x \partial y$ of

$$\partial_x E_y - \partial_y E_x = 0$$

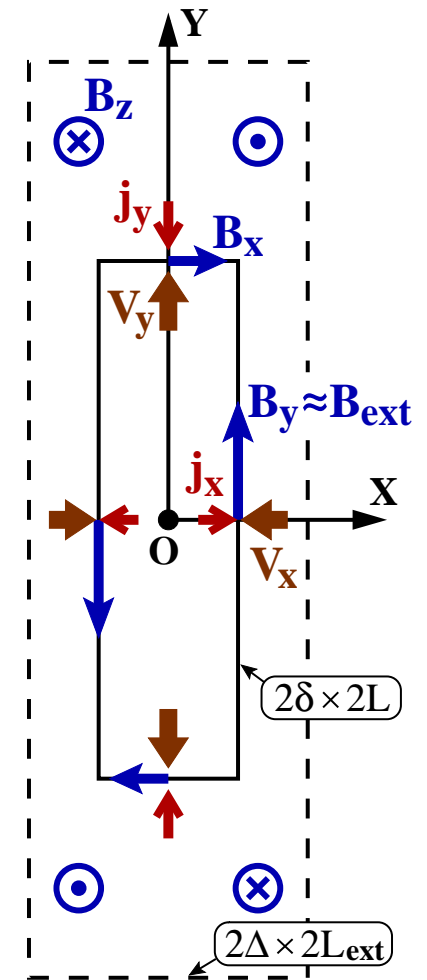

Equations (summary)

Ampere's Law (z-): 1 equation

Momentum Equation (y-): 1 equation

Faraday's and Ohm's Laws (x-, y-, z-): 6 equations

7 unknowns: j_o , δ , Δ , L , $(\partial_y V_y)_o$, $(\partial_y B_x)_o$, $(\partial_{xy} B_z)_o$
(equations partly replicate each other)

Find the unknowns and reconnection rate $E_z = \eta j_o$

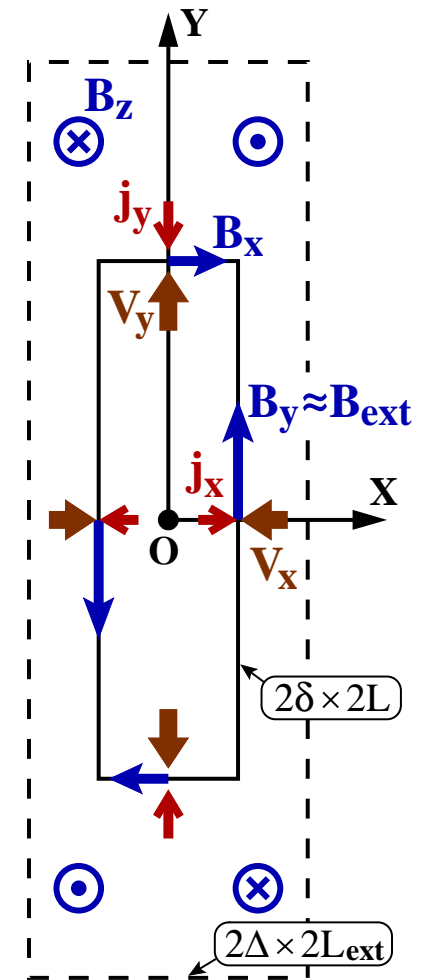

Solution

Convenient physical parameters:

$$V_A = \frac{B_{ext}}{\sqrt{nm_p}} \quad \text{is Alfvén velocity}$$

$$S = \frac{V_A L_{ext}}{\eta} \quad \text{is Lundquist number}$$

Convenient dimensionless parameter:

$$\tilde{\gamma} \equiv \frac{V_A d_p (\partial_{xy} B_z)_o}{B_{ext} (\partial_y V_y)_o} \approx \frac{(\mathbf{j} \times \mathbf{B})_z / ne}{(-\mathbf{V} \times \mathbf{B})_z}$$

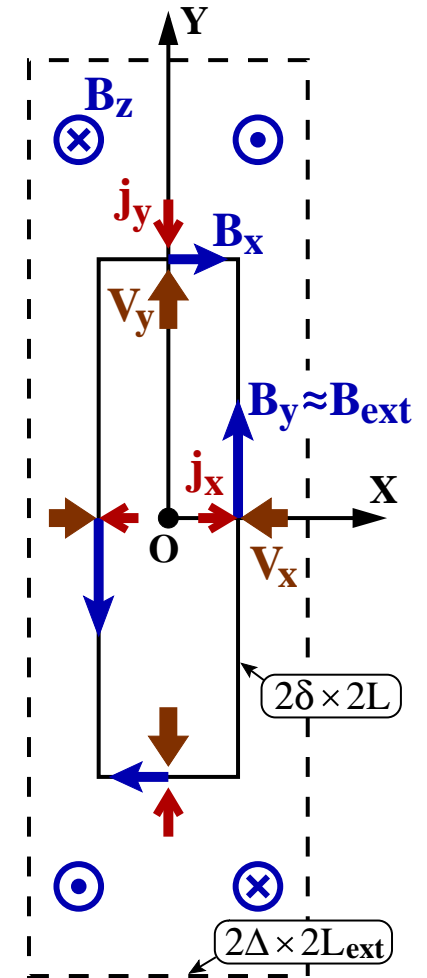

Solution: Sweet-Parker

Solution for $\tilde{\gamma} \lesssim 1$, Sweet-Parker reconnection regime

$$S \lesssim L_{ext}^2/d_p^2 \Rightarrow \delta \approx \Delta \gtrsim d_p$$

$$j_o \approx \frac{\sqrt{S} B_{ext}}{L_{ext}}, \quad E_z \approx \frac{1}{\sqrt{S}} V_A B_{ext}$$

$$\delta \approx \Delta \approx \frac{L_{ext}}{\sqrt{S}}$$

$$L \approx L_{ext}$$

$$\tilde{\gamma} \approx \frac{S d_p^2}{L_{ext}^2}$$

$$(\partial_y V_y)_o = \frac{V_A}{L_{ext}}, \quad V_y \approx V_A$$

$$(\partial_y B_x)_o \approx \frac{B_{ext}}{\sqrt{S} L_{ext}}, \quad (\partial_{xy} B_z)_o \approx \frac{S B_{ext} d_p}{L_{ext}^3}$$

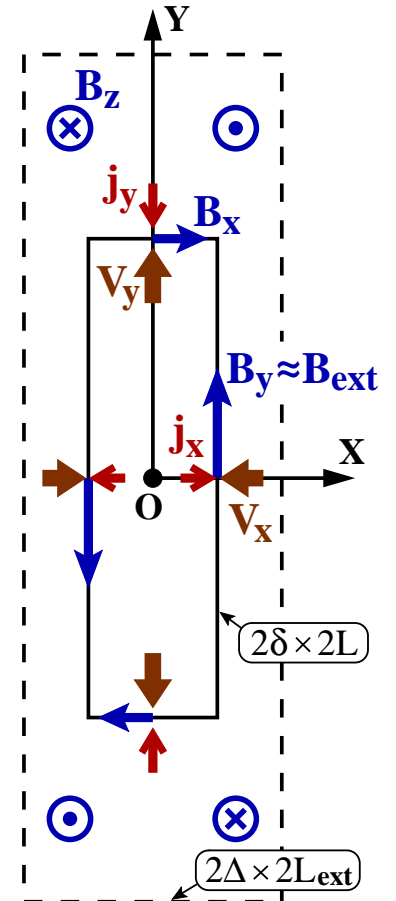
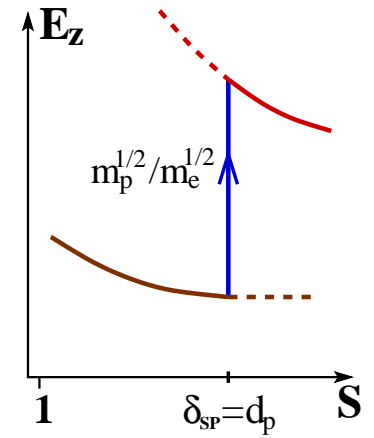

Solution: Hall

Solution for $1 \lesssim \tilde{\gamma} \lesssim d_p/d_e$, Hall reconnection regime

$$S \approx L_{ext}^2/d_p^2$$

$$L_{ext} \gtrsim L \gtrsim \frac{d_e L_{ext}}{d_p}, \quad j_o \approx \frac{L_{ext} B_{ext}}{d_p L}$$

$$E_z \approx \frac{d_p}{L} V_A B_{ext} \quad (\text{S. W. H. Cowley, 1985})$$

$$\delta \approx \frac{d_p L}{L_{ext}},$$

$$\Delta \approx d_p$$

$$\tilde{\gamma} \approx \frac{L_{ext}}{L}$$

$$(\partial_y V_y)_o = \frac{V_A}{L},$$

$$V_y \approx V_A$$

$$(\partial_y B_x)_o \approx \frac{d_p B_{ext}}{L_{ext} L},$$

$$(\partial_{xy} B_z)_o \approx \frac{B_{ext} L_{ext}}{d_p L^2}$$

Note: $B_z \approx (\partial_{xy} B_z)_o \delta L \approx B_{ext}$

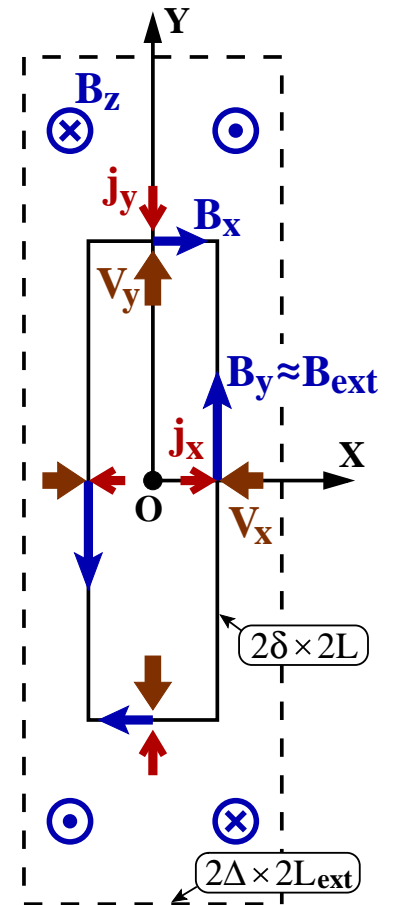
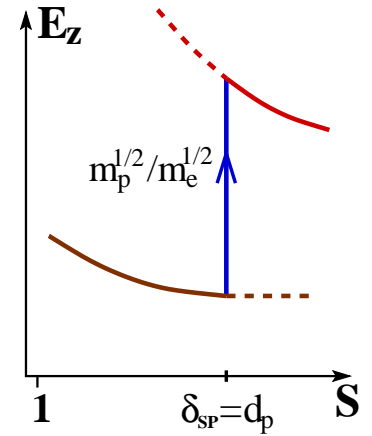

Solution: e-inertia

Solution for $d_p/d_e \lesssim \tilde{\gamma} < d_p^2/d_e^2$, **e-inertia regime**

$$j_o \approx \frac{B_{ext}}{d_e}$$

$$E_z \approx \frac{L_{ext}}{S d_e} V_A B_{ext} \approx \frac{d_p}{L} V_A B_{ext} \quad (\text{Zocco et al., 2008})$$

$$L \approx \frac{S d_e d_p}{L_{ext}}, \quad \delta \approx d_e, \quad \Delta \approx d_p$$

$$\frac{d_p}{d_e} \lesssim \tilde{\gamma} < \frac{d_p^2}{d_e^2}$$

$$(\partial_y V_y)_o = \frac{L_{ext} V_A}{S d_e^2 \tilde{\gamma}}, \quad (\partial_y V_y)_{x>\delta} \approx \frac{V_A}{L}$$

$$(\partial_y B_x)_o \approx \frac{L_{ext}^2 B_{ext}}{S^2 d_e d_p^2}, \quad (\partial_{xy} B_z)_o \approx \frac{B_{ext} L_{ext}}{S d_e^2 d_p}$$

Note: $B_z \approx (\partial_{xy} B_z)_o \delta L \approx B_{ext}$, $V_y(y \approx L_{ext}) \approx V_A$,
 $u_y^e \approx V_{Ae} = B_{ext} / \sqrt{nm_e}$

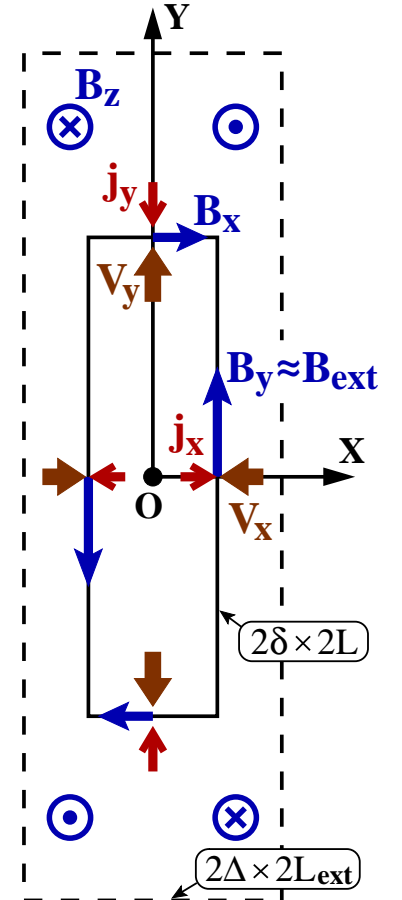
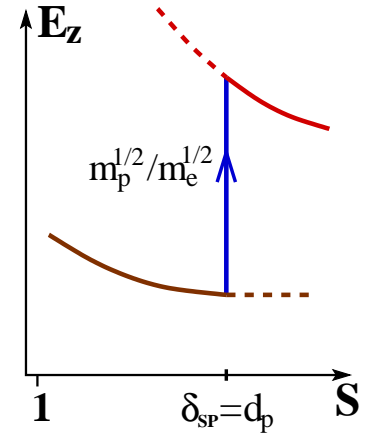

Summary

- e^- inertia term $d_e^2(\mathbf{j}\nabla)\mathbf{j} \approx m_e n(\mathbf{u}^e \nabla)\mathbf{u}^e$ enters the momentum equation:

$$m_p n [\partial_t \mathbf{V} + (\mathbf{V}\nabla)\mathbf{V}] + d_e^2(\mathbf{j}\nabla)\mathbf{j} = -\nabla P + \mathbf{j} \times \mathbf{B}$$

- There are slow Sweet-Parker and fast e-inertia-dominated regimes:

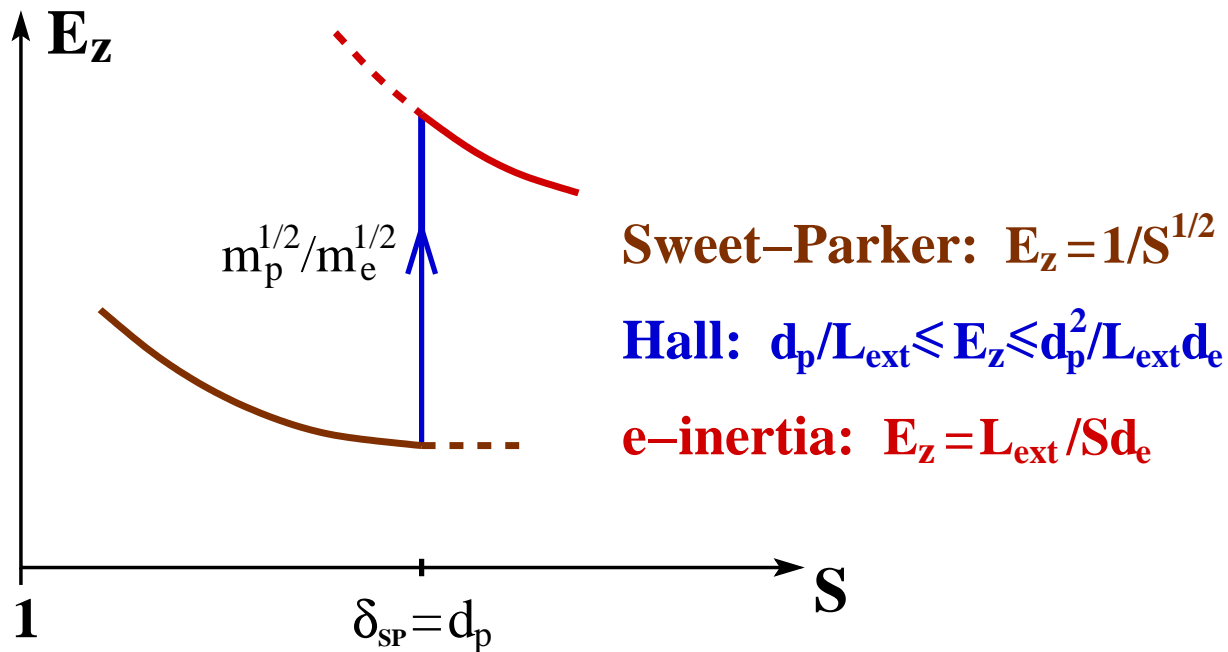

- <http://arxiv.org/abs/0904.0660>
- Need to account for anisotropy of the electron pressure tensor.

END

Equations: details

In equations spatial derivatives are assumed to be taken with respect to all indices listed after coma signs, for example, $B_{z,y} \equiv \partial_y B_z$ and $B_{z,xy} \equiv \partial_{xy} B_z$.

$$\tilde{\gamma} \equiv \frac{V_A d_p B_{z,xy}}{B_{ext} V_{y,y}} \approx \frac{\mathbf{j} \times \mathbf{B} / ne}{\mathbf{V} \times \mathbf{B}}, \quad en = \frac{B_{ext}}{d_p V_A}, \quad nm_p = \frac{B_{ext}^2}{V_A^2},$$

$$j_x = B_{z,y}, \quad j_y = -B_{z,x}, \quad j_{x,x} = -j_{y,y} = B_{z,xy}, \quad \eta = \frac{V_A L_{ext}}{S}$$

$$\frac{B_{ext}^2}{V_A^2} V_y V_{y,y} + d_e^2 j_y j_{y,y} = P_{,y} + j_z B_x$$

$$\frac{B_{ext}^2}{V_A^2} V_{y,y}^2 + d_e^2 B_{z,xy}^2 \approx \frac{2B_{ext}^2}{L^2} + j_o B_{x,y}$$

$$V_{out}^2 \approx V_A^2 \left[1 + \frac{L^2 j_o}{B_{ext}^2} \langle B_{x,y} \rangle_L \right]$$

$$\frac{L_{ext}V_A}{S}j_o = E_z = \frac{L_{ext}V_A}{S}j_z - V_x(B_y - d_e^2j_{z,x}) \left[1 - \frac{V_Ad_pj_x}{B_{ext}V_x} \left(1 + \frac{d_e^2}{d_p^2} \frac{V_Ad_pj_x}{B_{ext}V_x} \right) \right]$$

$$\frac{L_{ext}V_A}{S}j_o = E_z = \frac{L_{ext}V_A}{S}j_z + V_y(B_x + d_e^2j_{z,y}) \left[1 - \frac{V_Ad_pj_y}{B_{ext}V_y} \left(1 + \frac{d_e^2}{d_p^2} \frac{V_Ad_pj_y}{B_{ext}V_y} \right) \right]$$

$$- \frac{L_{ext}V_A}{2S}j_{z,xx} = V_{y,y}(B_{y,x} - d_e^2j_{z,xx}) \left[1 + \frac{V_Ad_pj_{x,x}}{B_{ext}V_{y,y}} \left(1 - \frac{d_e^2}{d_p^2} \frac{V_Ad_pj_{x,x}}{B_{ext}V_{y,y}} \right) \right]$$

$$- \frac{L_{ext}V_A}{2S}j_{z,yy} = V_{y,y}(B_{x,y} + d_e^2j_{z,yy}) \left[1 + \frac{V_Ad_pj_{x,x}}{B_{ext}V_{y,y}} \left(1 - \frac{d_e^2}{d_p^2} \frac{V_Ad_pj_{x,x}}{B_{ext}V_{y,y}} \right) \right]$$

$$\left(1 - \frac{d_e^2}{d_p^2} \frac{V_Ad_pj_{x,x}}{B_{ext}V_{y,y}} \right) [j_oj_{z,yy} + B_{x,y}(j_{z,xx} + j_{z,yy})] = \frac{L_{ext}B_{ext}}{Sd_p}(B_{z,xyxx} + B_{z,xyyy})$$

$$d_e^2B_{z,xy}^2 + \frac{2d_e^2B_{ext}}{d_pV_A}V_{y,y}B_{z,xy} + \frac{L_{ext}B_{ext}}{Sd_p}B_{z,xy} \approx \frac{2B_{ext}^2}{L^2} + j_oB_{x,y}$$

$$j_{z,xx} \approx -\frac{2j_o}{\delta^2}, \quad j_{z,yy} \approx -\frac{2j_o}{L^2}, \quad B_{z,xyxx} \approx -\frac{2B_{z,xy}}{\delta^2} \gg B_{z,xyyy},$$

$$B_{x,y} \ll B_{y,x} \approx j_o \approx \frac{B_{ext}}{\delta},$$

$$\tilde{\gamma} \equiv \frac{V_A d_p B_{z,xy}}{B_{ext} V_{y,y}} \approx \frac{\mathbf{j} \times \mathbf{B}/ne}{\mathbf{V} \times \mathbf{B}},$$

$$\frac{B_{ext}^2}{V_A^2} V_{y,y}^2 \left(1 + \frac{d_e^2}{d_p^2} \tilde{\gamma}^2 \right) \approx \frac{2B_{ext}^2}{L^2} + j_o B_{x,y}, \quad V_{out}^2 \approx V_A^2 \left[1 + \frac{L^2 j_o}{B_{ext}^2} \langle B_{x,y} \rangle_L \right]$$

$$\frac{L_{ext} V_A j_o^3}{S B_{ext}^2} \approx V_{y,y} j_o \left(1 + \frac{d_e^2 j_o^2}{B_{ext}^2} \right) \left[1 + \tilde{\gamma} \left(1 - \frac{d_e^2}{d_p^2} \tilde{\gamma} \right) \right], \quad \tilde{\gamma} \equiv \frac{V_A d_p B_{z,xy}}{B_{ext} V_{y,y}}$$

$$\frac{L_{ext} V_A j_o}{S L^2} \approx V_{y,y} \left(B_{x,y} - \frac{d_e^2 j_o}{L^2} \right) \left[1 + \tilde{\gamma} \left(1 - \frac{d_e^2}{d_p^2} \tilde{\gamma} \right) \right]$$

$$\left(1 - \frac{d_e^2}{d_p^2} \tilde{\gamma} \right) \left[j_o B_{x,y} + \frac{B_{ext}^2}{L^2} \right] = \frac{L_{ext} B_{ext}^2 V_{y,y}}{S d_p^2 V_A} \tilde{\gamma}$$

$$\frac{L_{ext} V_A}{S} j_o = E_z = \frac{L_{ext} V_A}{S} j_z - V_x (B_y - d_e^2 j_{z,x}) \left[1 - \frac{V_A d_p j_x}{B_{ext} V_x} \left(1 + \frac{d_e^2}{d_p^2} \frac{V_A d_p j_x}{B_{ext} V_x} \right) \right]$$

$$\frac{L_{ext} V_A}{S} j_o = E_z = \frac{L_{ext} V_A}{S} j_z + V_y (B_x + d_e^2 j_{z,y}) \left[1 - \frac{V_A d_p j_y}{B_{ext} V_y} \left(1 + \frac{d_e^2}{d_p^2} \frac{V_A d_p j_y}{B_{ext} V_y} \right) \right]$$

$$B_{x,y} \approx \frac{B_{ext}^2}{L^2 j_o} \left(1 + \frac{d_e^2 j_o^2}{B_{ext}^2} \right) \approx B_{x,y} - \frac{d_e^2 j_o}{L^2}, \quad j_o B_{x,y} + \frac{2B_{ext}^2}{L^2} \approx \frac{B_{ext}^2}{L^2} \left(1 + \frac{d_e^2 j_o^2}{B_{ext}^2} \right)$$